

Charge Islands Through Tunneling

Daryl C. Robinson*
 National Aeronautics and Space Administration
 Glenn Research Center
 Cleveland, Ohio USA
 Email: dcrobinson@grc.nasa.gov

ABSTRACT

It has been recently reported that the electrical charge in a semiconductive carbon nanotube is not evenly distributed, but rather it is divided into charge “islands” [1,2]. This paper links the aforementioned phenomenon to tunneling and provides further insight into the higher rate of tunneling processes, which makes tunneling devices attractive [3]. This paper also provides a basis for calculating the charge profile over the length of the tube so that nanoscale devices’ conductive properties may be fully exploited.

Keywords: Nanotube, Tunneling, Discrete, Trajectory, Charge

1 INTRODUCTION

Though it sounds futuristic, the idea of the warp tunnel is straightforward and sound, and it is essential for subsequent calculations in this paper. The concept of the warp tunnel is somewhat similar to Newton’s Cradle. The warp tunnel is introduced in Figure 1. When the black mass in Figure 1 is inserted into the warp tunnel, its representative exits almost immediately from the opposite end of the tunnel. If the warp tunnel is full, the effective distance traveled by the black mass in “its journey across the tube” is on the order of its diameter. The warp tunnel’s quantitative properties are derived here, based on Figure 2. m is the mass of the incoming or outgoing particle, and d its diameter. M is the mass of the average particle in the tube involved in the momentum transfer; D is the diameter of such a particle. The total mass of particles inside the tube is $M (r/D)$. g' is the acceleration due to an arbitrary force F acting on m and the particles inside the tube. So, $F = M (r/D) g'$, assuming $m \ll M (r/D)$. The equations of uniform acceleration give $d = g' t^2/2$, $t = (2 d/g')^{0.5}$. Pretending that the outgoing particle is identical to the incoming particle, we can define m ’s velocity across the tunnel, v_T , as

$$v_T = (r + d)/t = (r + d) (F/(2 d M (r/D)))^{0.5}.$$

Instead of F acting on a particle, we now assume it has a corresponding initial velocity v_i , then “it” will effectively traverse the tunnel with v_T . Now we calculate an input velocity v_i equivalent to F based on energy considerations:

$$m v_i^2/2 = F d, \text{ so } v_i = (2 F d/m)^{0.5}.$$



As the particle is inserted into the warp tunnel, “it” simultaneously emerges from the other end, independent of the length of the tunnel.

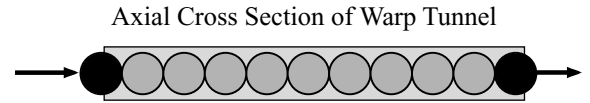

The nearly simultaneous emergence of “the” particle as it is inserted is illusory. Actually, the outgoing particle emerges as a consequence of tunnel overflow and is not the selfsame particle inserted, but effectively represents it.

Figure 1: The warp tunnel.

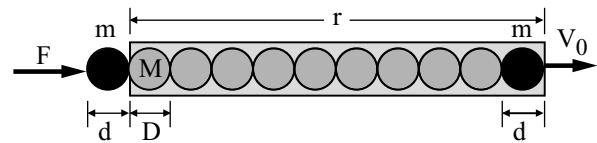

Figure 2: Auxiliary diagram for transmission velocity derivation.

$$\begin{aligned} v_T/v_i &= (r + d)/(2 d M (r/D))^{0.5} (m/(2 d))^{0.5} \\ &= (r + d) (m D)^{0.5}/(2 d)/(M r)^{0.5} \\ &\approx 0.5 (r/d) (m/M)^{0.5} (D/r)^{0.5}, \text{ if } r \gg d. \end{aligned}$$

An important conclusion of this analysis is that the incoming particle appears to traverse the tunnel with a velocity v_T that is much greater than its input or initial velocity v_i . The longer the tube is, the larger the mass, and the smaller the diameter or width of the inserted particle, the greater the speedup. However, due to conservation of energy, $v_0 \leq v_i$. In this paper, we assume that a warp tunnel spans a potential barrier. This analysis then provides insight into the higher rate of tunneling processes.

We derive inspiration from the optical tunneling scenario in Figure 3(a). When the upper right prism is removed, a detector to the right of the lower left prism and in-line with the incident beam detects nothing. However, when the upper right prism is brought into place, that same detector now detects. Feynman discusses this phenomenon in ref. [4]. Though no translating photons are in the gap, oscillating electrons on the lower left prism create an oscillating field, which shakes

* Mailing address: Mail Stop 54-5, 21000 Brookpark Road, Cleveland, Ohio 44135. Phone: 216-433-3553. Fax: 216-433-8705

electrons on the upper right prism, thereby producing the light captured by the detector.

We propose something similar for Figure 3(b). Electrons incident on the potential barrier do not actually enter the barrier, but rather produce photons free to enter the barrier instead. Through this action, electrons absorb energetic photons at the opposite end of the barrier. The energized electrons continue the motion once possessed by electrons on the other side of the barrier. In general, it is not the selfsame photon that enters the prism on the left that is detected beyond the prism on the right. Likewise, it is not the selfsame electron that impinges on the barrier in Figure 3(b) that emerges on the other side.

We regard the neutral gaps between charge islands as being spanned by a warp tunnel. These warp tunnels are full of photons, so full that the injection of a single photon at one end of the tunnel causes the ejection of another at the other end near another charge island. The ejected photon is absorbed by an electron; maintaining, by this mechanism, a discontinuous charge distribution.

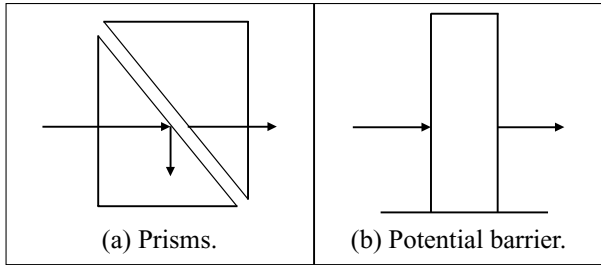

Figure 3: Optical and quantum mechanical tunneling.

2 SPACING CALCULATION

Since charge is segregated into islands, to model this structure, an appropriate circuit seems to be that of a series RC circuit. A capacitor plate represents a charge island; the spacing between the plates of the capacitor represents the neutral gaps between adjacent charge islands. The capacitors are modeled as having equal capacitance while R represents the resistance of everything in the circuit except the nanotube, since the nanotube is essentially treated as a capacitive element in this circuit (Figures 4 and 5). Ordinarily, we would not expect a capacitor to conduct a DC current, but if the plate spacing is sufficiently close, a tunneling current will flow in the same way that electrons tunnel through thin barriers. When tunneling is viewed in this new light, a tunneling current can readily transmit through 40 nm barriers.

Consider the warp tunnel in the top of Figure 1. Ignoring its coloring, let the particle entering the tunnel be a photon emitted by an electron, not displayed, to its left. Assume that the warp tunnel spans a barrier of width a . The particle emerging from the right side of the warp tunnel may be a photon that will be absorbed by an electron, not displayed, on the right side of the barrier. The outgoing photon thereby imparts that electron with the motion originally possessed by

the other electron on the left side of the barrier. In these calculations, it is assumed that the photon has a width, denoted “ l ,” directly proportional to its energy or frequency. The proportionality constant α is derived below.

Assuming the warp tunnel of length a in Figure 1 is full, the entering photon need only move into the tunnel an amount l when a representative photon will move out of the tunnel. The electron, which originally emitted the photon, has effectively bridged the distance across the barrier by “traveling” only a distance $l \ll a$. The effective length of the barrier is only l , the width or thickness of the atom of light of frequency f perpetuating the motion.

Figures 4 and 5, which depict a DC RC circuit, motivate the derivation of tunneling current formulae. While ordinarily only a transient current flows in response to the application of a constant DC voltage across the series RC couple, given a certain dielectric between the capacitor plates, Giaever showed in ref. [5] that if d_0 is small enough, a relatively constant tunneling current will flow, even for a DC power supply. We can obtain this result from the classical analysis of a DC RC circuit provided the capacitor plate separation is $d(t)$, a certain decreasing function of time, and where this d is a distinctly different variable from prior usages. From a mathematical perspective, the only $d(t)$ that allows for a

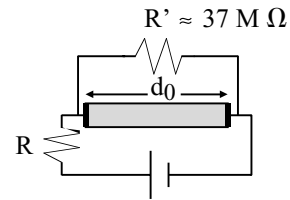

Figure 4: The nanotube is modeled as a resistor and capacitor in parallel. However, the resistance R' of the couple is very high so that it may be treated as an open circuit. R is the internal resistance of the circuit. It essentially includes resistance of the leads. R will be an essential parameter.

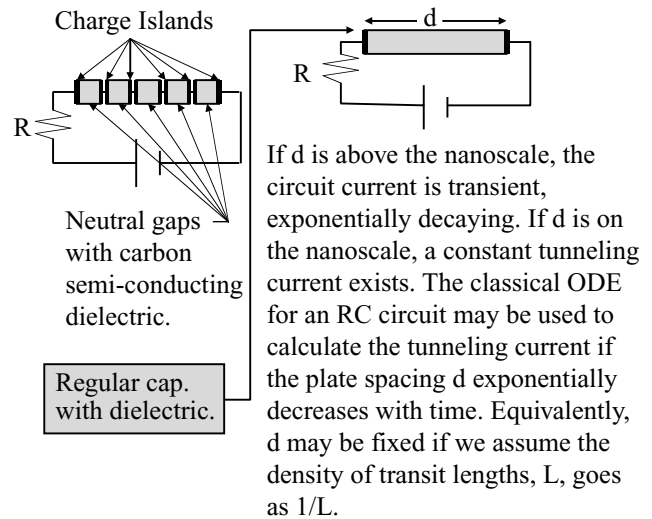

Figure 5: Charge islands modeled as charge on capacitor plates.

constant current in classical DC RC circuits is $d(t) = d_0 e^{-s^3 t}$, where s^3 is an undetermined constant. The capacitance C of the capacitor increases according to $C = s/(d_0 e^{-s^3 t}) \equiv s^2 e^{s^3 t}$, where s and s^2 are constants easily determined by the definition of capacitance. With that $d(t)$, we obtain a constant tunneling current through the capacitor, $I_c = (v/R) e^{-1/(R s^2 s^3)}$, which decreases exponentially with increasing initial barrier width d_0 . $d(t)$ corresponds to a probability density of effective transit lengths L inside the plates (the originally fixed plates) that varies as $1/(L s^3)$, a distribution that obviously favors shorter effective lengths. We assume, based on the model of a full warp tunnel, that the effective length of the barrier is about the width, lt , of a photon, and that the more energetic or the higher the frequency of a photon, the thicker it is ($lt = \alpha \omega$). For verification, the thermodynamic Planck Distribution Law for the distribution of radiation of various frequencies inside a cavity may then give us the density of effective lengths inside the barrier. Using the approximation $e^x \approx 1 + x$ for small x , the Planck Distribution [6] simplifies to:

$df = 1/(h \omega / (2 \pi \tau))$, where h is Planck's constant and τ is temperature.

So the density goes as $1/\omega = 1/[(lt/\alpha)] \propto 1/L$. This result is highly convincing, almost as much as the numbers that will be derived from it. Since the required distribution function for $d(t)$ is actually $df' = 1/(L s^3)$ [m^{-1}], if $L = lt = \alpha \omega$, thermodynamics gives

$df = df' = 1/(h \omega / (2 \pi \tau)) = 1/(\alpha \omega s^3)$ yielding $s^3 = h/(2 \pi \alpha \tau)$ [s^{-1}], where τ is in Joules.

To find α , now we derive an expression for the width of a photon as a function of its frequency. To derive an approximation for the size of a photon, we assume that its density is similar to that of a neutron, which essentially has the maximum known finite density in the observable universe.

We regard photons originating from both protons and electrons as having the density of a neutron. Since the proton is larger than the electron, the other charge quantum, it seems reasonable to approximate the upper size limit of one dimension of the photon by the radius of a proton [7].

As shown in Figure 6, if in its rest frame a mass is spherical, it will appear to observers in a rest frame viewing perpendicular to the uniform motion of the mass as having the profile of a convex lens or vertical ellipse, due to its length contraction in the direction of its motion. As the relative velocity between the perpendicular observers' frame and the frame of the mass increases, the width of the mass will decrease greatly while its height remains unaffected. In the limit, as the relative velocity approaches the speed of light, the mass will nearly have the profile of a rectangle. If observers are in a rest frame looking in a direction parallel to the motion of the mass as it approaches (a dead center view), the mass will appear circular. So from the combined views of those observing perpendicular and parallel to the motion of the mass, the mass has a shape approximated by a hockey

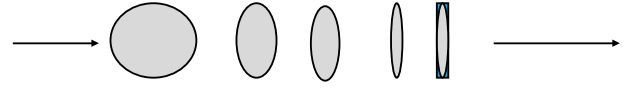

Figure 6: Snapshot view of a mass in a rest frame perpendicular to its velocity. Masses towards the right have a successively higher relative velocity with the rest frame. Images of masses towards the right are laterally compressed due to the relativistic length contraction. Right most mass is depicted as being encapsulated by a rectangle, which approximates its profile quite well.

puck or a short, fat cylinder, which has both a rectangular and circular profile. This mass, the subject of this discussion, is a photon. The width of the rectangular profile or the short height of the hockey puck or photon is referred to here as the light thickness or lt . The mass, m_p , of the photon is given by $m_p c^2 = h f$, where f is here used to represent the frequency as opposed to ν . The volume of the photon, v_p , is then the volume of a cylinder, $v_p = lt \pi r_p^2 = m_p/d' = h f/(c^2 d')$.

$$lt(f) = (h f / (c^2 d')) / (\pi r_p^2) \\ = 1.41 \times 10^{-39} f \text{ [m]}.$$

This result says that less energetic photons are thinner. We convert f into angular frequency: $f = \omega / (2 \pi)$.

$$lt(\omega) = 2.24 \times 10^{-40} \omega \text{ [m]} \\ \alpha = 2.24 \times 10^{-40} \text{ m s}.$$

For the temperature variable, we use room temperature, 298 K times B_k , Boltzmann's constant.

$$\tau = 298 B_k = 4.11 \times 10^{-21} \text{ J} \\ s^3 = h / (2 \pi \alpha \tau) = 1.15 \times 10^{26} \text{ s}^{-1}.$$

From ref. [8] we use the low-end dielectric constant for carbon powder, 2.5. We assume a diameter of 1 nm for the nanotube to obtain its circumference, $circ = 10^{-9} \pi$. We obtain 2.45 Å from refs. [9] and [10] as the parallel carbon bond separation or the contribution of each atom along the CNT's cross section towards the circumference (Figures 7 and 8). So the number of atoms, na , along the CNT's cross-section is $na = circ / 2.45 \times 10^{-10} = 12.82$.

The partial area, pa , an atom offers to its cross-section is obtained from refs. [9] and [10] as a double trapezoidal area with bases represented by the carbon bond length and the distance from opposite carbon atoms, and double height represented by the parallel carbon bond separation. So,

$$pa = ((2.83 + 1.42) \times 10^{-10}) (2.45 \times 10^{-10}) / 2 \text{ [m}^2\text{]} \\ = 5.21 \times 10^{-20} \text{ m}^2.$$

The cross-sectional area, a , of the circular wall of the CNT is $a = na pa = 6.68 \times 10^{-19} \text{ m}^2$. The permittivity of free space ϵ_0 is $8.85 \times 10^{-12} \text{ F/m}$.

$$s = kd \epsilon_0 a = 1.48 \times 10^{-29} \text{ F m}.$$

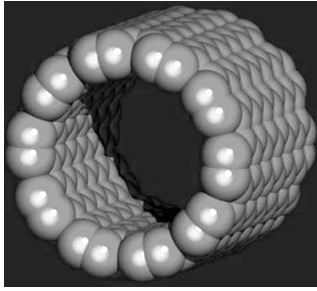

Figure 7: Section of single non-helical shell.

Equilibrium Structure	
Average Diameter of SWNT's	1.2-1.4 nm [1]
Distance from opposite Carbon Atoms (Line 1)	2.83 Å [1]
Analogous Carbon Atom Separation (Line 2)	2.456 Å [1]
Parallel Carbon Bond Separation (Line 3))	2.45 Å [1]
Carbon Bond Length (Line 4)	1.42 Å [1,23]

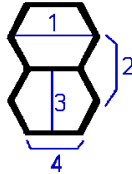

Figure 8: Distances used in calculations.

We may simplify the calculations by working with tunneling resistances as opposed to tunneling currents. The tunneling resistance of a capacitor is approximately given through this analysis as $R_T = R e^{1/(R s^2 s^3)}$.

Now we solve the tunneling equation to find resistances corresponding to the measured separations. If the resistances are reasonable, our model is as well. Careful experiments could be performed to check these resistances, which we hope would be an outcome of this paper. We equate the tunneling resistance of the entire nanotube with no islands at $t = 0$ when the power supply is switched on to that which would result from the known number n of charge islands which are manifested at $t > 0$:

$$\text{Exp}[d_0/(R s^3)] = n \text{Exp}[d_0/(n R s^3)],$$

where in the first case, since the model says the charge islands should be evenly spaced, $n = 650/40$. In the second case, $n = 750/36$.

Solving for R yields the internal circuit resistance for the given number of charge islands. The charge separations for various R have been calculated and are presented.

3 RESULTS

Results are given in the form: (R in Ohms, charge island spacing in nm). For the 650 nm tube, (0.0001270, 37.7), (0.0001316, 42.6), and (0.0001292, 40). For the 750 nm tube, (0.0001370, 34.4), (0.0001408, 37.82), and (0.0001389, 36). These resistances seem in range. They are very low resistances that appear to be what one would expect for the internal resistance of the circuit under consideration. The charge island spacing increases with R . Note that these results differ from those reported in ref. [11]. There we accidentally used the double trapezoidal height in calculating p_a , the incorrect

value of $9.08 \times 10^{16} \text{ kg/m}^3$ for the neutron density, an incorrect value for the proton radius, and also a value of 5 instead of 2.5 for the CNT dielectric constant.

4 CONCLUSIONS

This model allows one to conclude that the effective length of the barrier may be given by the width, $l_t(f)$, of a photon within the barrier. To find the probability density function, $f(L)$, of the length of the barrier, we use the Planck distribution function, which gives the thermal average number of photons in a single mode of frequency. For the temperature variable, we use room temperature. The majority of the frequencies are smaller than that of visible light; hence, $f(L) \propto 1/L$, where L is a function of frequency.

We return now to our classical RC circuit model. When the power is turned on in a classical DC RC circuit, we obtain a transient solution: a current that exponentially decays in time. However, if the capacitor plate spacing is not fixed, but is exponentially decreasing with increasing time, we find that the current through the capacitor is essentially constant and inversely exponentially depends on the original plate spacing. The probability distribution function, $g(L)$, of the length L between the capacitor plates, or the plate spacing, must give $g(L) \propto 1/L$ to explain a plate spacing that exponentially decays with time. This remarkable and highly convincing result shows that harmony may be obtained between standard tunneling current formulae and that predicted by DC RC circuit analysis by assuming that the tunneled current follows a discrete trajectory [11] across the barrier.

REFERENCES

- [1] G. Khitrov, "Carbon nanotubes electric charge divides into charge 'islands,'" MRS BULLETIN, pp. 4-5, July 2000.
- [2] Tans and Dekker, "Potential modulations along carbon nanotubes," Nature, 404, pp. 834-835, April 2000.
- [3] Linda Geppert, "Quantum transistors: toward nano-electronics," IEEE Spectrum, pp. 46-51, September 2000.
- [4] Feynman, The Feynman Lectures On Physics, Addison-Wesley Publishing Company, Inc. pp. 33-12 to 33-13, 1964.
- [5] Burstein and Lundqvist, Tunneling Phenomenon in Solids, Plenum Press, pp. 19-23, 1969.
- [6] Kittel and Kroemer, Thermal Physics, W.H. Freeman and Company, p. 91, 1980.
- [7] http://guinan.gsfc.nasa.gov/docs/xte/learning_center/ASM/ns.html
- [8] <http://www.asiinstr.com/dc1.html#SECTION-C>
- [9] <http://www.pa.msu.edu/cmp/csc/ntproperties/qfprint.html>
- [10] <http://www.msm.cam.ac.uk/polymer/members/msps100/CNT.html>
- [11] Robinson, Nanotube Tunneling as a Consequence of Probable Discrete Trajectories, Technical Proceedings of the 2001 International Conference on Computational Nanoscience, Computational Publications Publishing Office, pp. 77-80, 2001.